



www.DeepakPublishing.com

Chiesa, S. et al.. (2012): JoSS, Vol. 1, No. 1, pp. 31-44  
(Peer-reviewed article available at [www.jossonline.com](http://www.jossonline.com))



www.JoSSonline.com

# Design, Development and Test of Engineering Models of Tethered Nanosatellites to Observe the Solar Corona

S. Chiesa, V. Chillè, S. Corpino, A. Rougier, F. Stesina, And N. Viola

*Politecnico di Torino, Turin, Italy*

---

## Abstract

The present work, which is based on a cooperative effort between the Group of Space Solar Physics at the Osservatorio Astronomico di Torino (OATo), and the AeroSpace Systems Engineering Team (ASSET), at Politecnico di Torino, is part of a wider research program known as “Studies of Solar System Exploration,” funded in 2007 by ASI (Italian Space Agency). The request made by OATo was the development of the capability of taking pictures of the solar corona by means of simple and low cost optical components. ASSET developed the concept of a system consisting of two low-cost tethered nanosatellites, the Occulting and the Observing. The research program, which ended in 2010, envisaged both the conceptual design of the system and the development of experimental test-benches to test critical technologies. The following tests were performed in the Aerospace Systems Laboratory: attitude determination and control of the Occulting engineering model on a frictionless table; acquisition and transmission of pictures from the Observing engineering model to the control station; rotation of the Observing engineering model on a frictionless table; translation of the Observing engineering model on a frictionless table; and separation between the Occulting and Observing engineering models. This article summarizes the research activities carried out within the program and the primary results obtained.

---

## 1. Introduction

In the framework of the research project “Studies of Solar System Exploration,” funded by Italian Space Agency (ASI), the Group of Space Solar Physics at the Osservatorio Astronomico di Torino (OATo) and the

AeroSpace Systems Engineering Team (ASSET) at Politecnico di Torino began a cooperative study to develop the capability of taking pictures of the solar corona by means of simple and low-cost cameras, at the request of OATo. The study started in 2007 and ended in 2010.

ASSET developed the concept of a tether corona-graph system, i.e. a system consisting of two tethered nanosatellites, named respectively the “Occulting Satel-

---

*Corresponding Author: Nicole Viola – [Nicole.viola@polito.it](mailto:Nicole.viola@polito.it)*

Publication History: Submitted – 02/18/11; Revision Accepted – 11/22/11;  
Published – 04/06/12

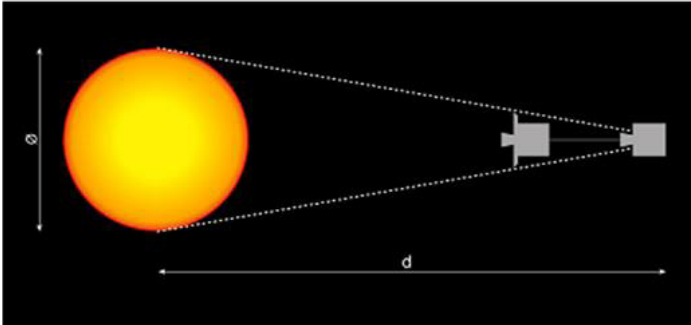

Figure 1. Tether coronagraph system concept.

lite” and the “Observing Satellite”, able to work together as a solar coronagraph (Figure 1) (Viola et al., 2008). The acronym that identifies this project is TWISTOSC, which stands for TWIn nanoSatellites To Observe the Solar Corona.

The tether coronagraph system is basically an externally-occulted coronagraph (personal communication: “Tether-Cor: Tethered Formation-Flying Coronagraph”, Fineschi, 2009). Externally-occulted coronagraphs are telescopes whose entrance pupil is in the shadow of a screen (“external occulter”) blocking the direct sunlight. This allows the observation of the solar corona that is several orders of magnitude fainter than the Sun. The distance between the external occulter (EO) and the entrance pupil (EP) is the parameter that determines how close to the solar limb the corona can be observed. The longer this distance is, the smaller is the view angle from the sun-center direction and the smaller are the diffraction effects.

In the single-bench coronagraphs currently in orbit the EO-EP distance is limited to 1-2 m. This type of coronagraph satellite has the capability of observing the solar corona at 2 solar radii (see Figure 2) by means of extremely complex optical devices.

By separating the EO and the EP on two different space platforms, the EO-EP baseline distance can be further extended. Two different approaches are possible: the formation-flying coronagraph and the tether coronagraph system. The former, which is currently under development (Wishart and Teston, 2007; Sjöberg et al., 2008), is characterized by an EO-EP distance of 150 m. It has the capability of observing the solar corona below 1.5 solar radii, thus enhancing the scientific requirement. However, in order to perform its mission,

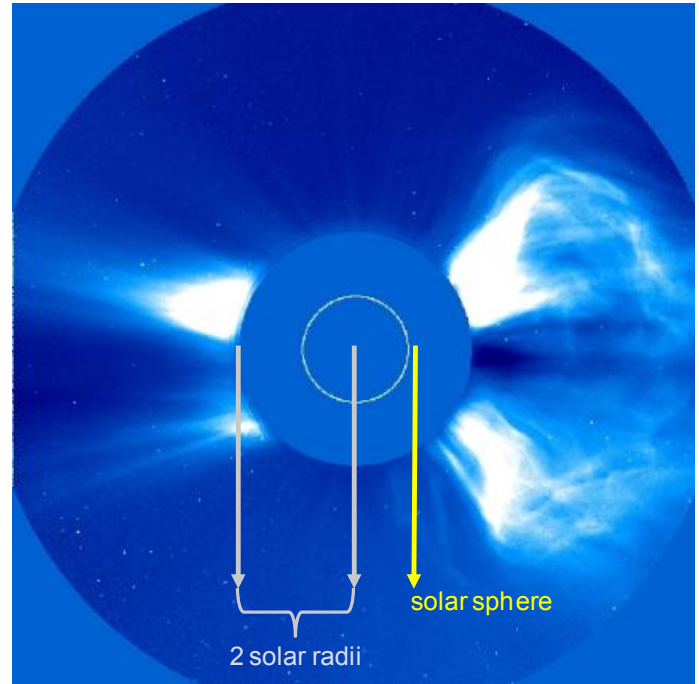

Figure 2. Solar sphere, solar corona and solar radius concept.

the mass of each platform exceeds one thousand kilograms (dry plus propellant mass). The latter (see Figure 3, showing the tethered coronagraph concept) is a novel approach, characterized by an EO-EP distance of tens of meters (specifically no less than 20 m). Taking into account an EO-EP distance of 20 m, the system has the capability of observing the solar corona at 2 solar radii with a mass of tens of kilograms per platform. Geometrical considerations show that the observation of the solar corona at 2 solar radii requires a maximum EO-EP misalignment of 0.2 degrees. Further increasing the EO-EP distance allows observation of the solar corona below 2 solar radii but the EO-EP alignment requirement becomes more severe.

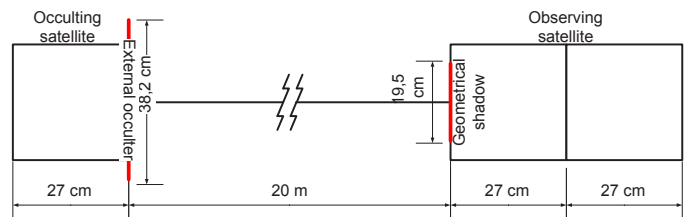

Figure 3. Tether coronagraph: the TWISTOSC concept.

In both cases, the formation-flying and the tether coronagraph, the optical devices are less complex, compared to those installed onboard the single-bench coronagraphs. Unlike the formation-flying concept, the tether coronagraph may be implemented by nanosatellites weighing tens of kilograms. However the dynamics and control of tethered system is not trivial, as all past tethered studies and missions testify (Carroll and Oldson, 1995; Carlson and Nakamura, 2000; Alfriend et al., 1995; Kruijff et al., 2008).

The TWISTOSC research program envisaged both the conceptual design of the tether coronagraph system (personal communication: “TWIn Satellite To Observe the Solar Corona: the TWISTOSC project”, Chiesa et al., 2009), and the development of experimental test-benches to test critical technologies (personal communication: “Occulting satellite engineering model”, Chiesa et al., 2010 and “Observing satellite engineering model and experimental test-benches”, Chiesa et al., 2010). The following sections deal with the primary results of the conceptual design and of the tests of the nanosatellite engineering models.

## 2. Conceptual Design

Regarding the conceptual design, on the basis of objectives and requirements, the mission analysis was accomplished and the system architecture defined through various iterations. This process ended with the complete system sizing, in terms of system mass, power and link budgets and subsystems component specifications.

As far as the system requirements are concerned (see Figure 4), it is worth emphasizing that the system guarantees that the top faces of the satellites are perpendicular to the solar vector and that the nanosatellites are aligned to the Sun. Both the mission objectives and the main top level system requirements are schematically represented in Figure 4, where the system requirements can be traced back to their correspondent mission objectives. This Figure also shows the most significant interactions between the main top level system requirements.

Through the functional analysis, these requirements led to the following actions: employment of

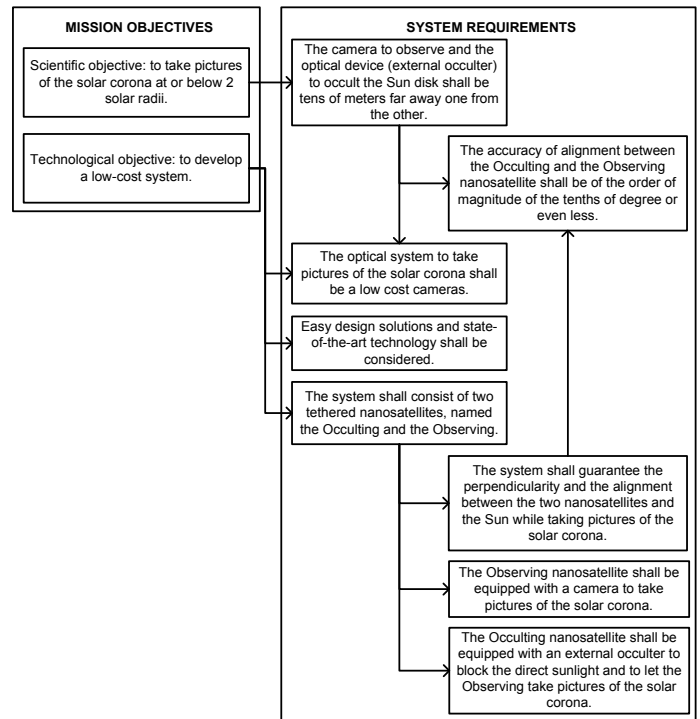

Figure 4. Mission objectives and system requirements.

sun sensors/inertial measurement unit and magnetic coils for, respectively, attitude determination and control and employment of optical sensors/laser telemeter and reaction control system (RCS) for, respectively, the relative position determination and control. Both the Occulting and the Observing nanosatellites are equipped with an Attitude Determination and Control System (ADCS), while only the Observing nanosatellite is equipped with an RCS. Apart from the RCS, all common systems are installed on board both nanosatellites (Electric Power, Onboard Data Handling, Communications, Structures, Payload and Thermal Control System – see Figures 5 and 6).

As for the mission analysis, a sun-synchronous orbit, with the Sun-Earth direction lying in the orbital plane, has been selected as the most promising to perform the mission (see Figure 7). As Figure 7 illustrates, various modes of operation have been envisaged for the orbital mission phase: the Payload Mode (PM), when the system takes pictures of the solar corona; the Communications Mode (CM), when the system communicates with ground stations; and the Idle Mode of operation (IM), when the system does not take pictures and

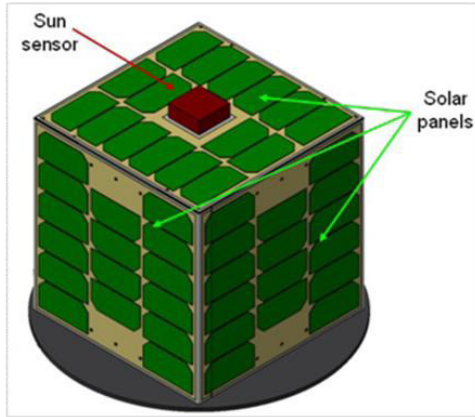

Figure 5. Occulting nanosatellite 3D CAD model.

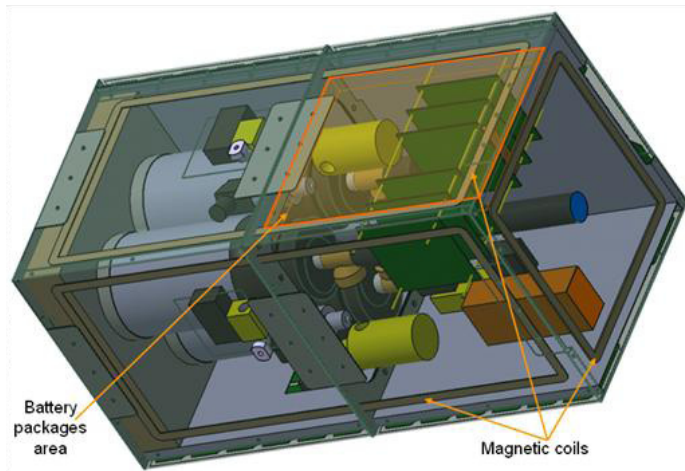

Figure 6. Observing nanosatellite 3D CAD model.

does not communicate. The percentage values shown in Figure 7 indicate the duty cycle of the ADCS and the RCS in the various modes of operation. In particular, during Payload Mode, the duty cycle of both ADCS and RCS is 5% to meet the system requirement, which expresses the accuracy of the alignment between the nanosatellites and the Sun vector. During Communications and Idle Modes, the duty cycle of both ADCS and RCS is 1% to limit possible misalignments between the nanosatellites and the nadir vector. As seen in Figure 7, taking into account the most promising orbit to perform the mission, PM extends over  $45^\circ$  and crosses the equator. Throughout the entire mode of operation, the tethered system must align to the Sun vector in compliance with the requirement of maximum EO-

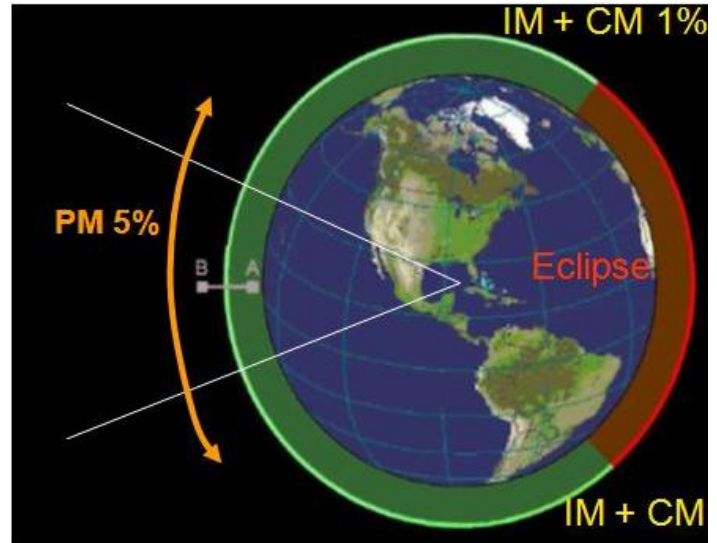

Figure 7. Mission orbit, system modes of operations (PM: Payload Mode, IM: Idle Mode and CM: Communications Mode), ADCS and RCS duty cycles (5% during PM and 1% during CM and IM) and system's configuration in PM (A: Occulting nanosatellite; B: Observing nanosatellite).

EP misalignment of 0.2 degrees, which is quite a strict requirement. However, it is worth remembering that the system must meet this requirement only in PM, i.e. only when the system, which normally aligns along the local vertical, does not have to perform critical maneuvers (high in-plane or out-of-plane angles) to move from the local vertical to the Sun vector direction.

Unlike PM, CM may occur anytime along the remaining part of the orbit when the system communicates with ground stations. Eventually, IM is the standard mission mode of operation when no Payload or Communications Modes are active. The Idle Mode may last up to 1.34 hours, while the Payload Mode and the Communications Mode may last respectively up to 0.21 and 0.16 hours.

With regard to system budgets, the main data regarding mass, peak power, average power (i.e. the peak power multiplied by the duty cycle) and power usage (i.e. the average power multiplied by duration) by mode of operation for the Occulting and the Observing nanosatellites are reported in Table 1. The presence of the RCS on board the Observing nanosatellite has determined its size and mass, which are bigger than those of the Occulting nanosatellite. The highest peak power

requirement occurs in PM, while the highest power usage happens in IM.

Table 1. Mass, Peak Power, Average Power and Power Usage of the Occulting and the Observing Nanosatellites.

		Occulting satellite	Observing satellite
Total mass [kg]		7	20
Peak power by mode [W]	PM	16	43
	CM	16	42
	IM	16	39
Average power by mode [W]	PM	9	12
	CM	8	14
	IM	8	10
Total power usage by mode [Wh]	PM	1	2
	CM	1	2
	IM	11	14

### 3. Experimental Test-Benches of the Nanosatellite Engineering Models

For the experimental test-benches, the following tests were performed in the Aerospace Systems Laboratory at Politecnico di Torino to test the critical technologies related to the TWISTOSC project:

- attitude determination and control of the Occulting engineering model on a frictionless table;
- acquisition and transmission of pictures from the Observing engineering model to the control station;
- rotation of the Observing engineering model on a frictionless table;
- translation of the Observing engineering model on a frictionless table; and
- separation between the Occulting and Observing engineering models.

In order to perform these tests, which are described in more detail in the following sections, a frictionless table, the Occulting and the Observing engineering models and a control station were designed and developed.

The frictionless table (see Figure 8) consists of a pane of glass 150 cm long, 120 cm wide and 1 cm thick, and an air pad system, which supplies the pads with compressed air, stored in a tank at 230 bar and 15 °C. Each pad has a load capacity of 88 N. In order to overcome problems of poor stability and symmetry, which would have badly affected the mobility of the satellites on the frictionless table, the pads were attached to the bottom of an interface adapter rather than directly to the bottom of the nanosatellite engineering model (see Figure 9).



Figure 8. The frictionless table.



Figure 9. The interface adapter, that supports the nanosatellite engineering model, and the air pad system, attached to the bottom of the interface adapter.

Figure 10 shows part of the frictionless table that was used to perform most of the tests; the interface

adapter, which is a cylindrical metallic structure; the Occulting engineering model, placed on top of the interface adapter; and a very simple and lightweight structure located on top of the Occulting engineering model to mechanically support the tank with compressed air.

Figures 11 and 12 present respectively the Occulting and the Observing engineering models, while Table 2 lists their main technical data in terms of mass, available electric power and size.

Figure 13 shows the control station, which is comprised of the following components:

- the pc and the radio module (Radio module 1 in Figure 14), which works at 2.4 GHz, to exchange commands and telemetry data between the control station itself and the Observing engineering model; and
- the TH-F7 radio (Radio in Figure 14), the SG7000 antenna, which works at 434 MHz, and one dedicated pc to receive and display the images, transmitted by the Observing engineering model.

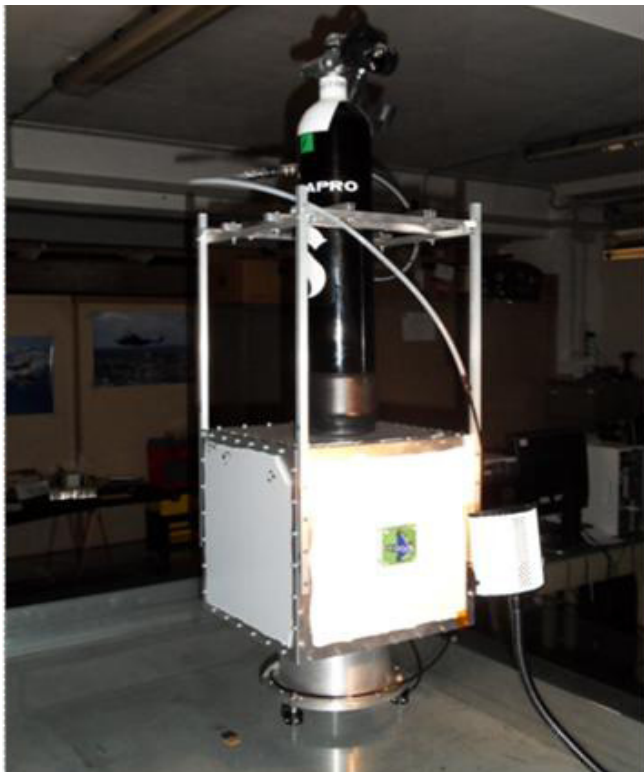

Figure 10. The frictionless table, the interface adapter, the Occulting engineering model and the ground support to the tank with compressed air.



Figure 11. Occulting engineering model.

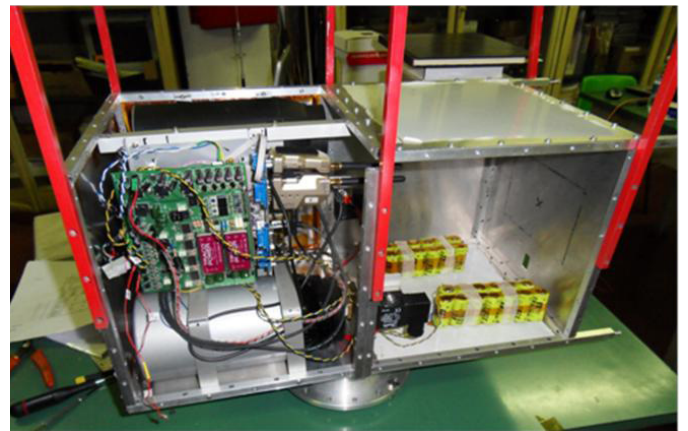

Figure 12. Observing engineering model.

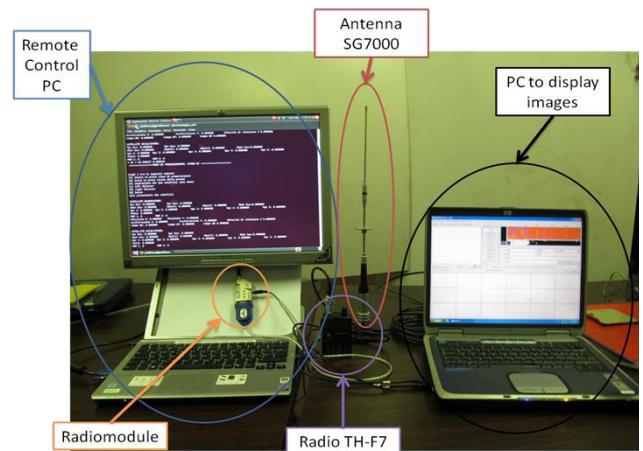

Figure 13. Control station.

Table 2. Mass, Battery Package and Dimensions of the Occulting and the Observing Nanosatellites.

Occulting engineering model			Observing engineering model		
Total mass with adapter and test equipment:		10 kg	Total mass with adapter and test equipment:		15.0 kg
NiCd battery package: 1 package of 13 batteries in series.	Nominal capacity of the single cell:	1800mAh	NiCd battery package: 1 package of 13 batteries in series.	Nominal capacity of the single cell:	1800 mAh
	Total voltage supplied by the battery package:	15.6 V		Total voltage supplied by the battery package:	15.6 V
Dimensions (single cube):		0.27 m	Dimensions (double cube):		0.27*2=54 m

As illustrated in Figure 14, the control station transmits the commands for both the Occulting and the Observing to the Observing engineering model, which then in turn transmits the commands for the Occulting by means of another radio module (Radio module 2 in Figure 14). The same happens for the transmission of telemetry data from the satellite engineering models to the control station.

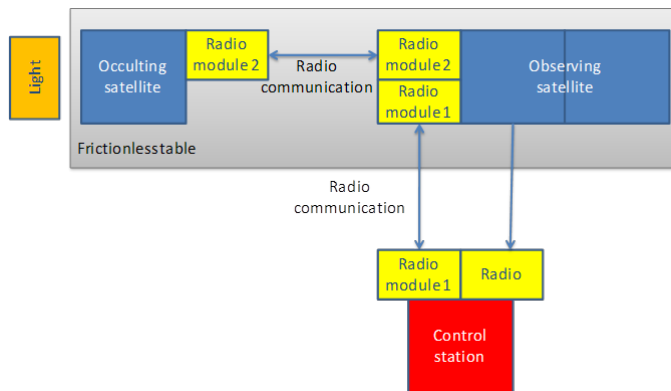

Figure 14. Communications between the control station, the Observing and the Occulting engineering models.

### 3.1 Attitude Determination and Control of the Occulting Engineering Model on the Frictionless Table

The aim here was to test and verify technology, equipment, and software useful for the attitude determination and control of the Occulting nanosatellite on the bi-dimensional plane. Before performing the test, the following steps were taken:

- design of the test with the final result of the defini-

tion of the functional block diagram of the test-bench (see Figure 15);

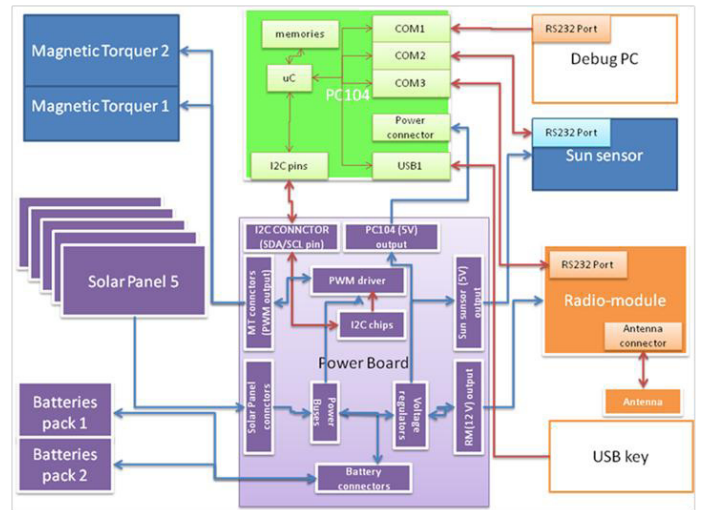

Figure 15. Functional block diagram of the test “Attitude determination and control of the Occulting engineering model on the frictionless table”.

- design, development and test of custom equipments: the sun sensor for the attitude determination (see Figure 16), the magnetic torquers for the attitude control (see Figure 11, where the magnetic torquer is attached to the inner face of the Occulting engineering model), the electric power electronic board (see Figure 17) and the structure;
- design, development and test of custom software: C code to determine and control the attitude and to manage satellite operations; and
- integration of the Occulting engineering model

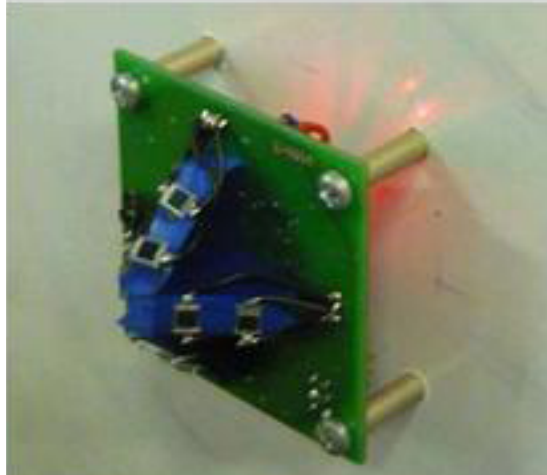

Figure 16. Sun sensors.



Figure 17. Electric power electronic board.

(see Figures 11 and 15 for the final result of the integration process), which is comprised of two magnetic torquers, two battery packages, one electric power electronic board (“Power Board” in Figure 15), one onboard data handling electronic board (“PC 104” in Figure 15), one sun sensor, located on the outer face of the Occulting engineering model (see Figure 10) and one radio module to allow communications between the Occulting engineering model and the control station.

The test was performed according to the following step-by-step procedure:

- the Occulting engineering model (located on top of the interface adapter), together with the air pads (attached to the bottom of the interface adapter), and the tank (placed on top of the Occulting engineering model within its support structure) is positioned on the frictionless table;
- the air pad system is switched on and the Occulting engineering model starts moving freely on top of the frictionless table, until stabilization is reached.
- This first phase of stabilization guarantees that the successive rotations of the engineering model are due only to the control torques generated by the magnetic torquers;
- the control station transmits a command to the

Occulting engineering model to make the sun sensor align to the source of light.

- In order to carry out the test, the Occulting engineering model and the following Ground Support Equipment (GSE) was used:
- the frictionless table, which must be as smooth as possible and perfectly horizontal;
- the air pad system, which is made up of three air pads, one tank, pipes and valves;
- the interface adapter;
- the structure to support the tank on top of the Occulting engineering model;
- the control station;
- one table lamp as source of light; and
- one digital chronometer.

The result of the test was the achievement of the desired attitude with a rotational speed of about 1 degree per second and an accuracy of about 0.2 degree.

### 3.2 Acquisition and Transmission of Pictures from the Observing Engineering Model to the Control Station

The aim was to test and verify algorithms, equipment, and technologies useful for the acquisition and transmission of pictures, using low cost technologies

and commercial off the shelf components. Before performing the test, the following steps were taken:

- design of the test with the final result of the definition of the functional block diagram of the test-bench (see Figure 18);
- design, development and test of custom equipment: the communications electronic board dedicated to the transmission of the images and the structure; and
- design, development and test of custom software: C code for data and images acquisition from optical sensor (the webcam) and for images transmission and reception through audio codification

The test was performed according to the following step-by-step procedure:

- test of the C code software programs for the acquisition, transmission and reception of images performed by means of the pc desktop and the embedded pc;
- test of the integrated C code software program for both acquisition of images by means of the webcam and transmission of images by means of the custom communications electronic board through the pc desktop.

In order to carry out the test of the integrated C code software program, the communications electronic board and the radio module of the Observing engineering model were used to, respectively, transmit images to the control station and to receive commands and transmit data from/to the control station. Apart these equipment of the Observing engineering model, the following GSE was used (see Figure 19):

- the control station;
- the pc desktop, which plays the role of the onboard data handling of the Occulting engineering model and it is therefore connected to the communications electronic board; and
- the power pack to supply the communications electronic board with electric power.

The result of the test was the transmission of

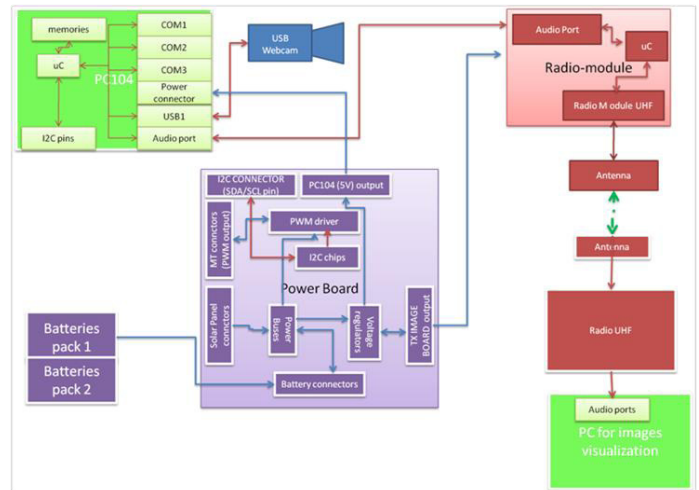

Figure 18. Functional block diagram of the test “Acquisition and transmission of pictures from the Observing engineering model to the control station.”

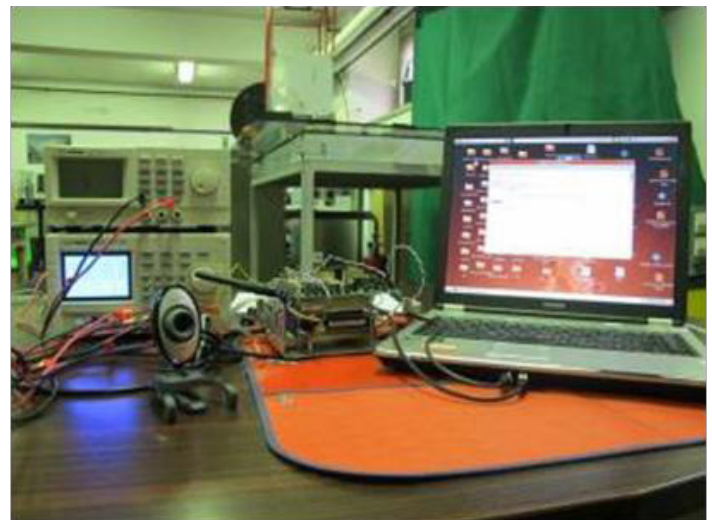

Figure 19. The pc desktop, the communications electronic board, the radio module, the webcam and the power pack.

320x240 pixel images, which took slightly more than 2 minutes.

### 3.3 Rotation of the Observing Engineering Model on the Frictionless Table

The aim was to test and verify technology, equipment, and software useful for the rotation of the satellite on the bi-dimensional plane (see Figure 20).

Before performing the test, the following steps were

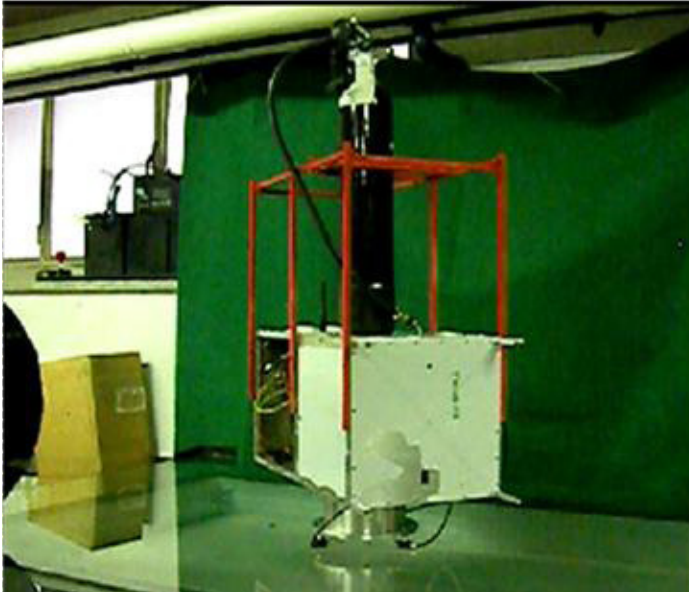

Figure 20. Tests of rotation and translation of the Observing engineering model on the frictionless table.

taken:

- design of the test with the final result of the definition of the functional block diagram of the test-bench (see Figure 21);
- design, development and test of custom equipments: the magnetic torquers for the satellite rotation, the electric power electronic board (see Figure 17) and the structure;
- design, development and test of custom software: C code to make the satellite rotate and to manage satellite operations; and
- integration of the Observing engineering model (see Figures 12 and 21 for the final result of the integration process), which is comprised of two magnetic torquers, two battery packages, one electric power electronic board (“Power Board” in Figure 21), one onboard data handling electronic board (“PC 104” in Figure 21), two electro-valves and the corresponding two thrusters, tanks and valves of the Reaction Control System (RCS) and two radio modules to allow communications between the Observing engineering model and the control station and between the Occulting and the Observing engineering models.

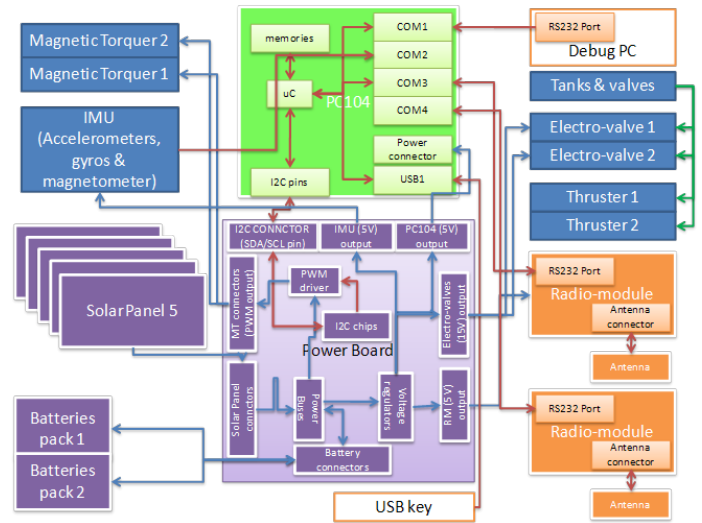

Figure 21. Functional block diagram of the tests “Rotation of the Observing engineering model on the frictionless table” and “Translation of the Observing engineering model on the frictionless table.”

The test was performed according to the following step-by-step procedure:

- the Observing engineering model (located on top of the interface adapter), together with the air pads (attached to the bottom of the interface adapter, and the tank, placed on top of the Observing engineering model within its support structure, is positioned on the frictionless table;
- the air pad system is switched on and the Observing engineering model starts moving freely on top of the frictionless table, until stabilization is reached. This first phase of stabilization guarantees that the successive rotations of the engineering model are due only to the control torques generated by the magnetic torquers;
- the control station transmits a command to the Observing engineering model to make it rotate by means of the control torque generated by the magnetic torquers. It is worth remembering that the test does not aim at determining the attitude of the Observing engineering model.

In order to carry out the test, the Observing engineering model and the following GSE was used:

- the frictionless table, which must be as smooth as possible and perfectly horizontal;
- the air pad system, which is made up of three air pads, one tank, pipes and valves;
- the interface adapter;
- the structure to support the tank on top of the Observing engineering model;
- the control station; and
- one digital chronometer.

The result of the test was the rotation of the satellite engineering model at a rotational speed of 1 degree per second.

### **3.4 Translation of the Observing Engineering Model on the Frictionless Table**

The aim here was to test and verify technology, equipment and software useful for the translation of the satellite on the bi-dimensional plane (see Figure 20).

Before performing the test, the following steps were taken:

- design of the test with the final result of the definition of the functional block diagram of the test-bench (see Figure 21);
- design, development and test of custom equipments: the thrusters, that are convergent nozzle able to generate a thrust of about 0.02 N and are the actuators of the reaction control system (see Figure 22), the electric power electronic board (see Figure 17) and the structure;
- design, development and test of custom software: C code to command the electro-valves, connected to the thrusters, and to manage satellite operations; and
- integration of the Observing engineering model.

The test was performed according to the following step-by-step procedure:

- the Observing engineering model (located on top of the interface adapter), together with the air pads

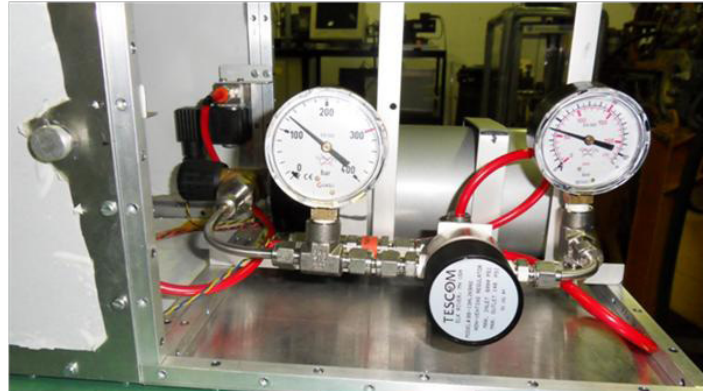

Figure 22. Reaction control system of the Observing engineering model.

(attached to the bottom of the interface adapter) and the tank (placed on top of the Observing engineering model within its support structure), is positioned on the frictionless table;

- the air pad system is switched on and the Observing engineering model starts moving freely on top of the frictionless table, until stabilization is reached. This first phase of stabilization guarantees that the successive translations of the engineering model are due only to the forces generated by the thrusters;
- the control station transmits a command to the Observing engineering model to make it translate along the frictionless table by the forces generated
- by the thrusters. It is worth remembering that the test does not aim at determining the position of the Observing engineering model.

In order to carry out the test, the Observing engineering model and the following GSE was used:

- the frictionless table, which must be as smooth as possible and perfectly horizontal;
- the air pad system, which is made up of three air pads, one tank, pipes and valves;
- the interface adapter;
- the structure to support the tank on top of the Observing engineering model;
- the control station; and
- one digital chronometer.

The result of the test was the translation of satellite engineering model at a speed of 3 centimeters per second.

### 3.5 Separation Between the Occulting and Observing Engineering Models

The aim was to test and verify technology, equipment, and software useful for the command of the undocking and the subsequent separation of the Occulting and the Observing engineering models on the bi-dimensional plane (see Figure 23).

Before performing the test, the following steps were taken:

- design, development and test of custom equipments/subsystem: the subsystem for the undocking/separation of the engineering models, which is comprised of one latch (see Figure 24) and one electro-mechanical winch (see Figure 25), the electric power electronic board (see Figure 17) and the structure; and
- design, development and test of custom software: C code to command the latch and to manage satellite operations.



Figure 23. Test of separation between the Occulting and Observing engineering models.

The test was performed according to the following step-by-step procedure:



Figure 24. Undocking/separation subsystem: the latch.

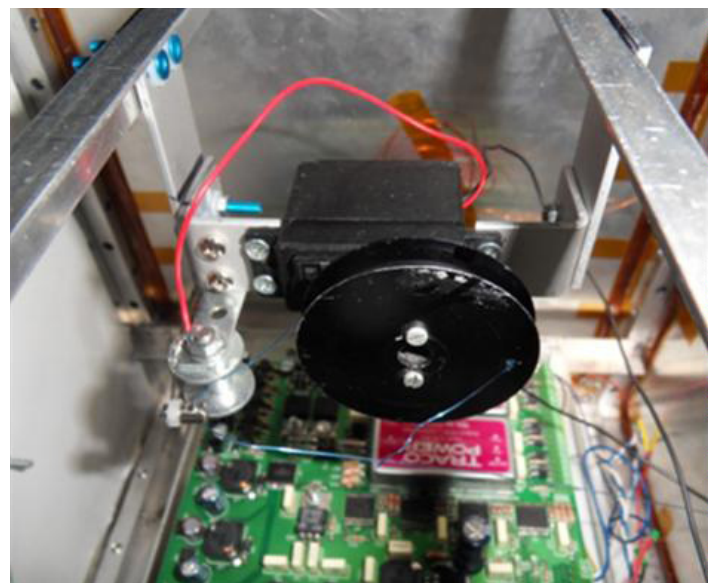

Figure 25. Undocking/separation subsystem: the electro-mechanical winch.

- the Occulting engineering model is placed in a fixed position on the frictionless table;
- the Observing engineering model (located on top of the interface adapter), together with the air pads (attached to the bottom of the interface adapter) and the tank (placed on top of the Observing engineering model within its support structure), is positioned on the frictionless table;
- the air pad system is switched on and the Observ-

ing engineering model starts moving freely on top of the frictionless table, until stabilization is reached;

- the Occulting and the Observing engineering models are aligned and the latch between them is fastened; and
- the control station transmits a command to the Observing engineering model to unfasten the latch, thus making the Observing undock from the Occulting engineering model. After unfastening the latch, the electro-mechanical winch is activated, thus making the Observing separate from the Occulting engineering model.

In order to carry out the test, the Observing and the Occulting engineering models and the following GSE was used:

- the frictionless table, which must be as smooth as possible and perfectly horizontal;
- the air pad system, which is made up of three air pads, one tank, pipes and valves;
- the interface adapter;
- the structure to support the tank on top of the Observing engineering model;
- the control station; and
- one digital chronometer.

The result of the test was the undocking and separation of the Observing from the Occulting satellite engineering model, which took 5 seconds to reach 25 centimetres.

#### **4. Conclusions and Future Works**

The paper presents the main results of the TWIS-TOSC program within the “Studies of Solar System Exploration” project. The TWISTOSC program aims at developing the capability of taking pictures of the solar corona by means of simple and low-cost optical components through a system consisting of two low-cost tethered nanosatellites, the Occulting and the Observing. The paper focuses in particular on the main results

of the overall system’s conceptual design and the tests performed by means of experimental test-benches to validate and verify critical technologies.

The experimental test-benches were useful to verify the feasibility of the tether coronagraph - the TWIS-TOSC concept - which is a low-cost system employing state-of-the art technologies, and to identify crucial technologies that need to be further investigated. In particular, envisaged for the near future are:

- a more detailed mission analysis, extended to all flight phases, and investigation of a system able to meet the requirement of 0.06 deg of maximum misalignment for a EO-EP distance of 30 m (capability of observing the solar corona below 1.5 solar radii; and
- development of the complete attitude determination and control, as well as the position determination and control of the Observing satellite.

#### **Acknowledgments**

The authors wish to thank Prof. Ester Antonucci and Silvano Fineschi (OATo) for their invaluable support in defining the payload characteristics.

---

#### **References**

- Alfriend, K.T., et al. (1995): Attitude and Orbit Determination of a Tethered Satellite System, in *Proc. AAS/AIAA Astrodynamics Conference*, Halifax, Nova Scotia.
- Carlson, J. and Nakamura, Y. (2000): The Kyushu/US Experimental Satellite Tether (QUEST) Mission, a Small Satellite to Test and Validate Spacecraft Tether Deployment and Operations, in *Proc. 14th AIAA/USU Small Satellite Conference*, Logan, UT.
- Carroll, J., A. and Oldson, J., C. (1995): Tethers for Small Satellite Applications, in *Proc. AIAA/USU Small Satellite Conference*, Logan, UT.
- Kruijff, M., et al. (2008): First Mission Results of the YES2 Tethered SpaceMail Experiment. AIAA-2008-7385, in *Proc. AIAA/AAS Astrodynamics Spe-*

*cialist Conference*, Honolulu, HI.

Sjöberg, F. et al. (2008): High Precision Formation Flying Guidance, Navigation and Control for the PROBA-3 Mission, in *Proc. 59th International Astronautical Congress*, Glasgow, Scotland.

Viola, N., et al. (2008): Tethered Nano-satellites to Observe the Solar Corona, in *Proc. 59th International Astronautical Congress*, Glasgow, Scotland.

Wishart, A., and Teston, F. (2007): The PROBA-3 Formation Flying Technology Demonstration Mission, in *Proc. 58th International Astronautical Congress*, Hyderabad, India.